

# DIRECTIONAL VALVE

Parts List		
Number	Description	Material
1	Valve body	AISI 316
2	Fastening clamp	---
3	Pneumatic actuator	Galvanized steel

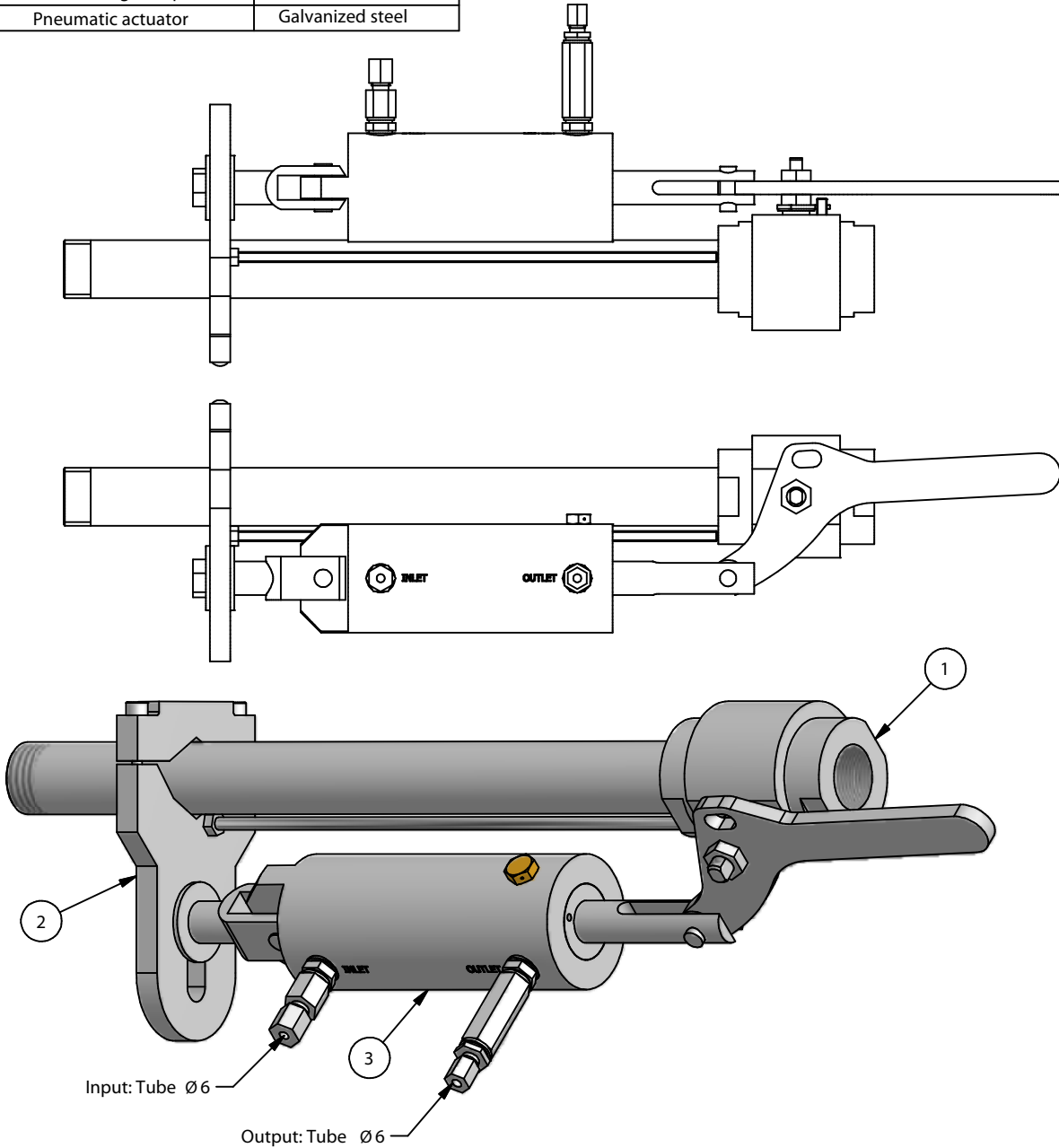

### Specifications

Reference	AEX/VDAR114	AEX/VDAR2	AEX/VDAR3	AEX/VDAR4
Maximum working pressure (valve)	400 bar	400 bar	400 bar	65 bar
Maximum working pressure (actuator)	400 bar	400 bar	400 bar	400 bar
Test pressure	1100 bar	1100 bar	1100 bar	1100 bar
Minimum actuation pressure	30 bar	30 bar	30 bar	30 bar
Working temperature	-20°C / +90°C	-20°C / +90°C	-20°C / +90°C	-20°C / +90° C
Weight	16 Kg	24 Kg	40 Kg	50 Kg
Valve connection	Female 1 1/4" NPT	Female 2" NPT	Female 3" NPT	Female 4" NPT

Description: Valve used to protect more than one risk with the same cylinder or cylinder battery.

Code sheet:	Group sheet:	Reference:	Drawn:	Date:	Revised:	Date:	Review:	Format:
AEX-FTC-09-068	IG-55	VER TABLA	DCM	12/02/2018	MRC	12/02/2018	1	A4